



DC-UPS CONTROL UNIT

- Requires Only One 12V Battery for a 24V Output
- Stable Output Voltage in Buffer Mode
- Superior Battery Management for Longest Battery Life
- Comprehensive Diagnostic and Monitoring Functions
- Replace Battery Signal Included
- Electronically Overload and Short Circuit Protected
- 50% Power Reserves
- Selectable Buffer Time Limiter
- 3 Year Warranty

1. GENERAL DESCRIPTION

This uninterruptible power supply (UPS) controller UB10.241 is an addition to standard 24V power supplies to bridge power failures or voltage fluctuations. Expensive downtimes, long restart cycles and loss of data can be avoided.

The DC-UPS includes a professional battery management system which charges and monitors the battery to achieve the longest battery service life as well as many diagnostic functions that ensure a reliable operation of the entire system.

A unique feature of the UB10.241 is that only one 12V battery is required to buffer the 24V output. This makes matching batteries unnecessary and allows a precise battery charging and testing.

The UB10.241 requires one external 12V battery for which two preassembled battery modules are available. A lightweight 7Ah battery which can be mounted on the DIN-Rail and a 26Ah module that can be panel mounted for longer buffer times.

In addition to the UB10.241, the UBC10.241 UPS includes the same controller with an integrated 5Ah battery.

2. SHORT-FORM DATA

Input voltage	nom. 24Vdc	
range	22.5-30Vdc	
Output current	min. 15A	Normal mode
	min. 10A	Buffer mode
Output voltage	typ. 0.23V lower	Normal mode
	as input voltage	
	22.25V	Buffer mode, 10A
Allowed batteries	3.9Ah to 40Ah	VRLA lead acid
Temperature range	-25 to +70°C	Operational
		+60°C to +70°C
Derating	0.43A/°C	normal mode
Dimensions	49x124x117mm	WxHxD
Buffer time (at 10A)	typ. 6'45"	7Ah battery module
	typ. 55'	26Ah batt. module

Typical setup of a DC-UPS system with the UB10.241:

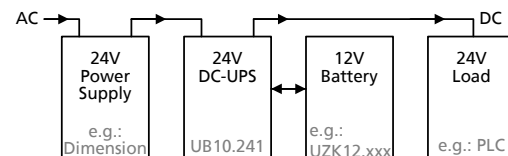

3. ORDER NUMBERS

DC-UPS	UB10.241	Standard controller
Accessories	UZK12.071	Battery module 12V 7Ah
	UZO12.07	Mounting kit w/o battery
	UZK12.261	Battery module 12V 26Ah
	UZO12.26	Mounting kit w/o battery
	ZM1.WALL	Panel/Wall mount bracket

4. MARKINGS



June. 2010 / Rev. 1.3 DS-UB10.241-EN

All parameters are specified at an input voltage of 24V, 10A output load, 25°C ambient and after a 5 minutes run-in time unless otherwise noted. It is assumed that the input power source can deliver a sufficient output current.

INDEX PAGE

1. General Description	1
2. Short-form Data	1
3. Order Numbers	1
4. Markings	1
5. Input	3
6. Output in Normal Mode	4
7. Output in Buffer Mode	5
8. Battery Input	6
9. Buffer Time	7
10. Efficiency and Power Losses	9
11. Functional Diagram	9
12. Check Wiring and Battery Quality Tests	10
13. Relay Contacts and Inhibit Input	11
14. Front Side User Elements	13
15. Terminals and Wiring	14
16. Reliability	14

INDEX PAGE

17. EMC	15
18. Environment	16
19. Protection Features	16
20. Safety	17
21. Approvals	17
22. Fulfilled Standards	17
23. Used Substances	18
24. Physical Dimensions and Weight	18
25. Installation Notes	19
26. Accessories	20
27. Application Notes	21
27.1. Battery Replacement Intervals	21
27.2. Parallel and Serial Use	22
27.3. Using the Inhibit Input	23
27.4. Troubleshooting	23

INTENDED USE

The unit shall only be installed and put into operation by qualified personnel.

This unit is designed for installation in an enclosure and is intended for general use, such as in industrial control, office, communication, and instrumentation equipment. Do not use this device in aircraft, trains and nuclear equipment, where malfunctioning of the power supply may cause severe personal injury or threaten human life.

TERMINOLOGY AND ABBREVIATIONS

DC-UPS	Uninterruptible power supply with DC-Input.
Normal mode	Describes a condition where the battery is charged, the input voltage is in range and the output is loaded within the allowed limits.
Buffer mode	Describes a condition where the input voltage is below the transfer threshold level, the unit is running on battery (buffering) and the output is loaded within the allowed limits.
Charging mode	Describes a condition where the battery is being charged, the input voltage is in range and the output is loaded within the allowed limits.
Inhibit mode	Describes a condition where buffering is disabled on purpose by using the inhibit input of the DC-UPS. (e.g. for service actions, or to save battery capacity)
Buffer time	Same as the term "hold-up time".
T.b.d.	To be defined, value or description will follow later.

DISCLAIMER

The information presented in this document is believed to be accurate and reliable and may change without notice. Some parts of this unit are patent by PULS (US patent No 091662,063, Des. 424,529, ...).

No part of this document may be reproduced or utilized in any form without permission in writing from the publisher.

5. INPUT

Input voltage	nom.	DC 24V	
Input voltage ranges	nom.	22.5 to 30Vdc 30 to 35Vdc 35Vdc 0 to 22.5Vdc	Continuous operation, see Fig. 5-1 Temporarily allowed, no damage to the DC-UPS *) Absolute maximum input voltage with no damage to the DC-UPS The DC-UPS switches into buffer mode and delivers output voltage from the battery if the input was above the turn-on level before and all other buffer conditions are fulfilled.
Allowed input voltage ripple	max.	1.5Vpp 1Vpp	Bandwidth <400Hz Bandwidth 400Hz to 1kHz
Allowed voltage between input and earth (ground)	max.	60Vdc or 42.4Vac	
Turn-on voltage	typ.	22.8Vdc	The output does not switch on if the input voltage does not exceed this level.
	max.	23Vdc	
Input current **)	typ.	120mA 1.1A	Internal current consumption Current consumption for battery charging in constant current mode at 24V input See Fig. 8-2 ***)
External capacitors on the input	No limitation		

*) The DC-UPS shows "Check Wiring" with the red LED and buffering is not possible

***) The total input current is the sum of the output current, the current which is required to charge the battery during the charging process and the current which is needed to supply the DC-UPS itself. See also Fig. 5-2. This calculation does not apply in overload situations where the DC-UPS limits the output current, therefore see Fig. 5-3.

***) Please note: This is the input current and not the current which flows into the battery during charging. The battery current can be found in chapter 8.

Fig. 5-1 Input voltage range

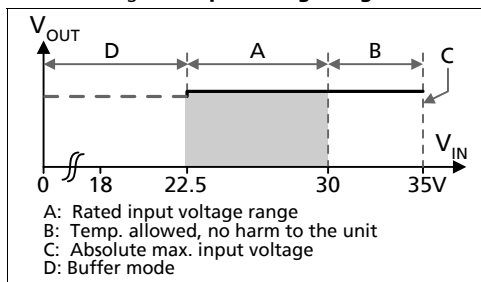
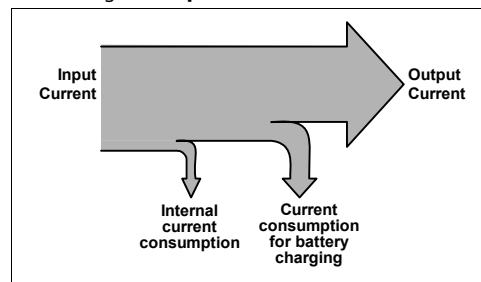

Fig. 5-2 Input current, definitions



Electronic output current limitation

The DC-UPS is equipped with an electronic output current limitation. This current limitation works in a switching mode which reduces the power losses and heat generation to a minimum. As a result, the output voltage drops since there is not enough current to support the load. A positive effect of the current limitation in switching mode is that the input current goes down despite an increase in the output current resulting in less stress for the supplying source.

Fig. 5-3 Input current and output voltage vs. output current, typ. (battery fully charged)

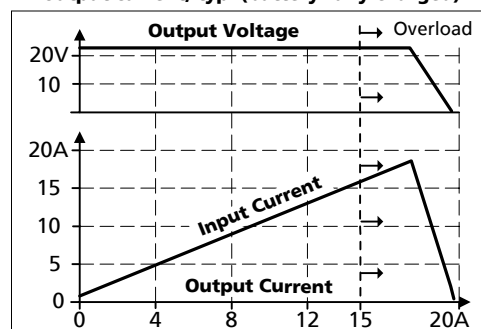

June. 2010 / Rev. 1.3 DS-UB10.241-EN

All parameters are specified at an input voltage of 24V, 10A output load, 25°C ambient and after a 5 minutes run-in time unless otherwise noted. It is assumed that the input power source can deliver a sufficient output current.

7. OUTPUT IN BUFFER MODE

If the input voltage falls below a certain value (transfer threshold level), the DC-UPS starts buffering without any interruption or voltage dips. Buffering is possible even if the battery is not fully charged.

Output voltage in buffer mode	nom.	DC 24V	Output voltage is stabilized and independent from battery voltage
		22.45V	±1%, at no load,
		22.25V	±1%, at 10A output current
Transfer threshold for buffering	typ.	80mV higher than the output voltage in buffer mode	
Ripple and noise voltage	max.	20mVpp	20Hz to 20MHz, 50Ohm
Output current	nom.	10A	Continuously allowed
		15A	< 5s with full output voltage *)
Short-circuit current	min.	17.9A	Load impedance 100mOhm **)
	max.	21A	Load impedance 100mOhm **)

- *) If the output current is in the range between 10A and 15A for longer than 5s, a hardware controlled reduction of the maximal output current to 10A occurs. If the 10A are not sufficient to maintain the 24V, buffering stops after another 5s. The buffering is possible again as soon as the input voltage recovers.
- ***) If the nominal output voltage cannot be maintained in buffer mode, the DC-UPS switches off after 5s to save battery capacity.

Fig. 7-1 Buffering transition, definitions

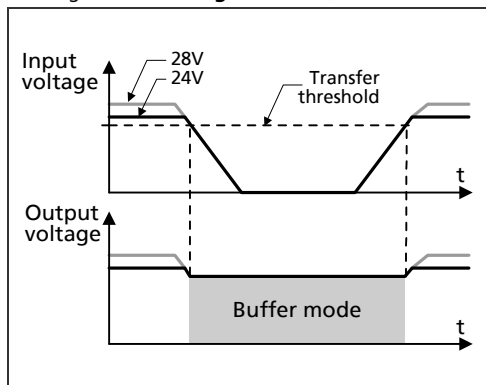

Fig. 7-2 Transfer behavior, typ.

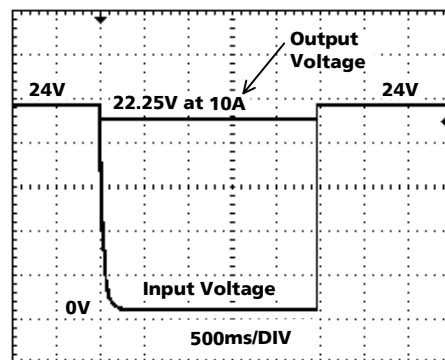

Fig. 7-3 Available output current in buffer mode

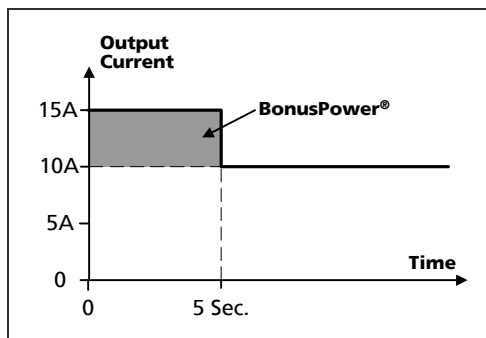
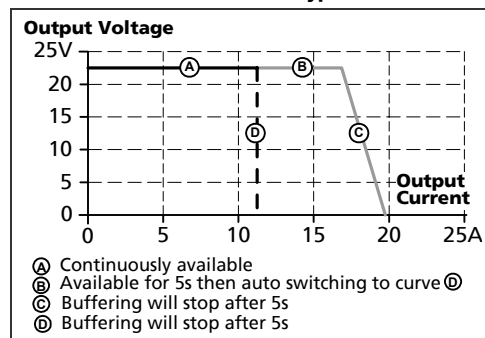

Fig. 7-4 Output voltage vs. output current in buffer mode, typ.



8. BATTERY INPUT

The DC-UPS requires one 12V VRLA battery to buffer the 24V output.

Battery voltage	nom.	DC 12V	Use one maintenance-free 12V VRLA lead acid battery or one battery module which is listed in the chapter accessories.
Battery voltage range		9.0 – 15.0V	Continuously allowed, except deep discharge protection Absolute maximum voltage with no damage to the unit Above this voltage level battery charging is possible
	max.	35Vdc	
	typ.	7.4V	
Allowed battery sizes	min.	3.9Ah	
	max.	40Ah	
Internal battery resistance	max.	100mOhm	See individual battery datasheets for this value
Battery charging method		CC-CV	Constant current, constant voltage mode
Battery charging current (CC-mode)	nom.	1.5A	Independent from battery size, Corresponding 24V input current see Fig. 8-2
	max.	1.7A	
End-of-charge-voltage (CV-mode)		13.4-13.9V	Adjustable, see chapter 14
Battery charging time	typ.	5h *)	For a 7Ah battery
	typ.	17h *)	For a 26Ah battery
Battery discharging current **)	typ.	21A	Buffer mode, 10A output current, 11.5V on the battery terminal of the DC-UPS, see Fig. 8-1 for other parameters
	typ.	0.3A	Buffer mode, 0A output current
	max.	50µA	At no input, buffering had switched off, all LEDs are off
	typ.	270mA	At no input, buffering had switched off, yellow LED shows "buffer time expired" (max. 15 minutes)
Deep discharge protection ***)	typ.	10.5V	At 0A output current
	typ.	9.0V	At 10A output current

*) The charging time depends on the duration and load current of the last buffer event. The numbers in the table represent a fully discharged battery. A typical figure for a buffer current of 10A is 3h 20Min. for a 7Ah battery.

***) The current between the battery and the DC-UPS is more than twice the output current. This is caused by boosting the 12V battery voltage to a 24V level. This high current requires large wire gauges and short cable length for the longest possible buffer time. The higher the resistance of the connection between the battery and the DC-UPS, the lower the voltage on the battery terminals which increases the discharging current. See also chapter 25 for more installation instructions.

***) To ensure longest battery lifetime, the DC-UPS has a battery deep discharge protection feature included. The DC-UPS stops buffering when the voltage on the battery terminals of the DC-UPS falls below a certain value. The yellow LED will show "buffer time expired" for a period of 15 minutes after the unit stopped buffering.

Fig. 8-1 Battery discharging current vs. output current, typ.

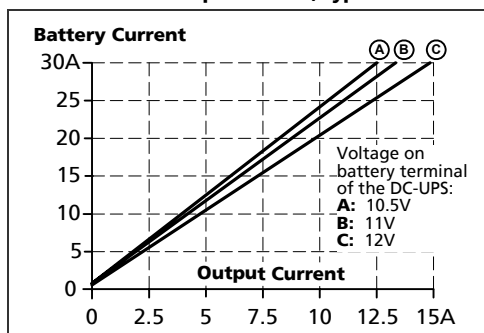
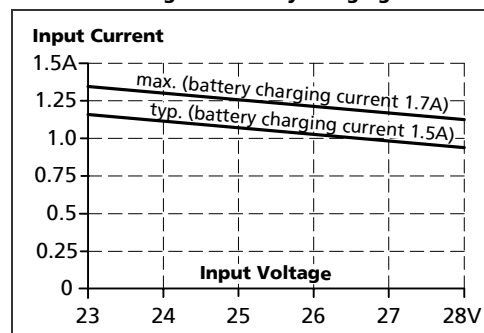

Fig. 8-2 Required input current vs. input voltage for battery charging



9. BUFFER TIME

The buffer time depends on the capacity and performance of the battery as well as the load current. The diagram below shows the typical buffer times of the standard battery modules.

Buffer time with battery module UZK12.071	min.	19'12"	At 5A output current *)
	min.	5'42"	At 10A output current *)
	typ.	21'30"	At 5A output current, see Fig. 9-1 **)
	typ.	6'45"	At 10A output current, see Fig. 9-1 **)
Buffer time with battery module UZK12.261	min.	99'30"	At 5A output current *)
	min.	39'	At 10A output current *)
	typ.	130'	At 5A output current, see Fig. 9-1 **)
	typ.	55'	At 10A output current, see Fig. 9-1 **)

*) Minimum value includes 20% aging of the battery and a cable length of 1.5m with a cross section of 2.5mm² between the battery and the DC-UPS and requires a fully charged (min. 24h) battery.

***) Typical value includes 10% aging of the battery and a cable length of 0.3m with a cross section of 2.5mm² between the battery and the DC-UPS and requires a fully charged (min. 24h) battery.

Fig. 9-1 Buffer time vs. output current with the battery modules UZK12.071 and UZK12.261

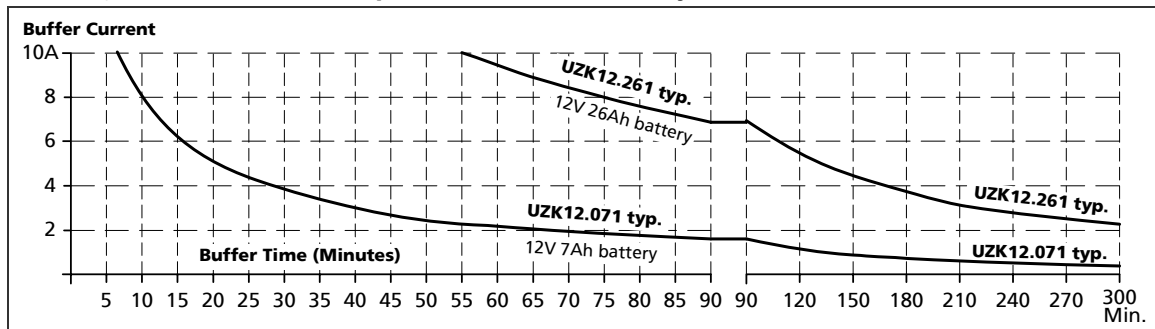

The battery capacity is usually specified in amp-hours (Ah) for a 20h discharging event. The battery discharge is non-linear (due to the battery chemistry). The higher the discharging current, the lower the appropriate battery capacity. The magnitude of the reduction depends on the discharging current as well as on the type of battery. High current battery types can have up to 50% longer buffer times compared to regular batteries when batteries will be discharged in less than 1 hour.

High discharging currents do not necessarily mean high power losses as the appropriate battery capacity is reduced with such currents. When the battery begins to recharge after a discharging event, the process is completed much faster since only the energy which was taken out of the battery needs to be "refilled".

For this reason, the buffer time cannot be calculated using the Ah capacity value. The equation " $I \times t = \text{capacity in Ah}$ " generally leads to incorrect results when the discharging current is higher than C20 (discharging current for 20h). The battery datasheet needs to be studied and a determination of the expected buffer time can be made according to the following example:

Example how to determine the expected buffer time for other battery types and battery sizes:

Step 1 Check the datasheet of the battery which is planned to be used and look for the discharging curve. Sometimes, the individual discharging curves are marked with relative C-factors instead of current values. This can easily be converted. The C-factor needs to be multiplied with the nominal battery capacity to get the current value. E.g.: 0.6C on a 17Ah battery means 10.2A.

Fig. 9-2 Typical discharging curve of a typical 17Ah battery, curve taken from a manufacturer's datasheet

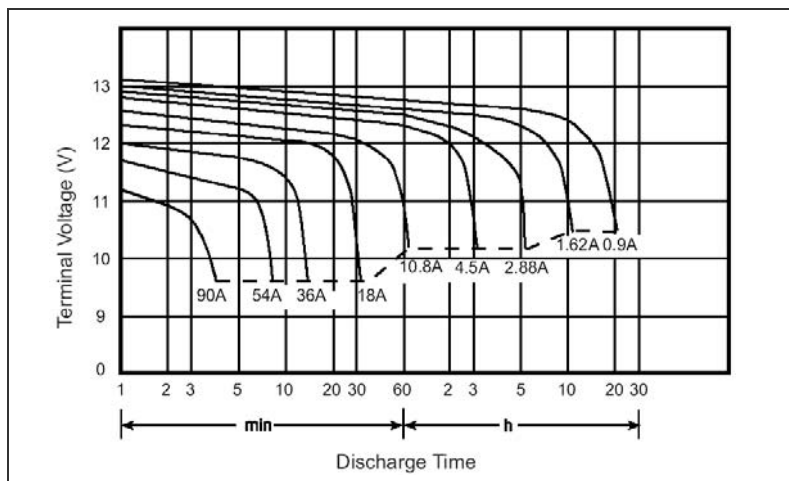

Step 2 Determine the required battery current. Use Fig. 8-1 "Battery discharging current vs. output current" to get the battery current. Fig. 8-1 requires the average voltage on the battery terminals. Since there is a voltage drop between the battery terminals and the battery input of the DC-UPS, it is recommended to use the curve A or B for output currents > 3A or when long battery cables are used. For all other situations, use curve C.

Step 3 Use the determined current from Step 2 to find the appropriate curve in Fig. 9-2. The buffer time (Discharging Time) can be found where this curve meets the dotted line. This is the point where the DC-UPS stops buffering due to the under-voltage lockout.

Step 4 Depending on Fig. 9-2, the buffer time needs to be reduced to take aging effects or guaranteed values into account.

Example:

The buffer current: is 7.5A and a battery according Fig. 9-2 is used. The cable between the battery and the DC-UPS is 1m and has a cross section of 2.5mm². How much is the maximum achievable buffer time.

Answer:

- According to Fig. 8-1, the battery current is 18A. Curve A is used since the battery current is > 3A and the length of the cable is one meter.
- According to Fig. 9-2, a buffer time (Discharging Time) of 30 Minutes can be determined. It is recommended to reduce this figure to approximately 24 minutes for a guaranteed value and to cover aging effects.

10. EFFICIENCY AND POWER LOSSES

Efficiency	typ.	97.8%	Normal mode, 10A output current, battery fully charged
Power losses	typ.	2.9W	Normal mode, 0A output current, battery fully charged
	typ.	5.5W	Normal mode, 10A output current, battery fully charged
	typ.	5.0W	During battery charging, 0A output current
	typ.	18.5W	Buffer mode, 10A output current

Fig. 10-1 Efficiency at 24V, typ.

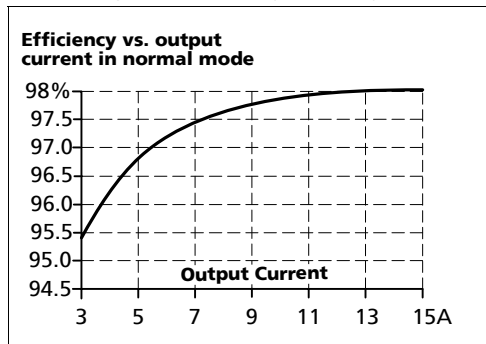
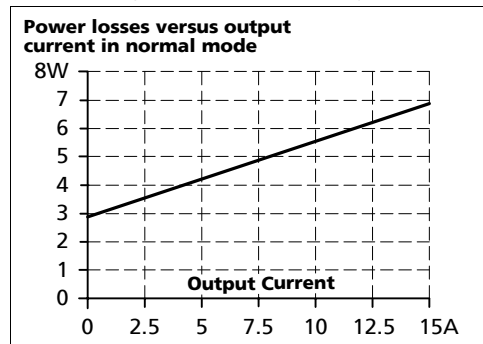
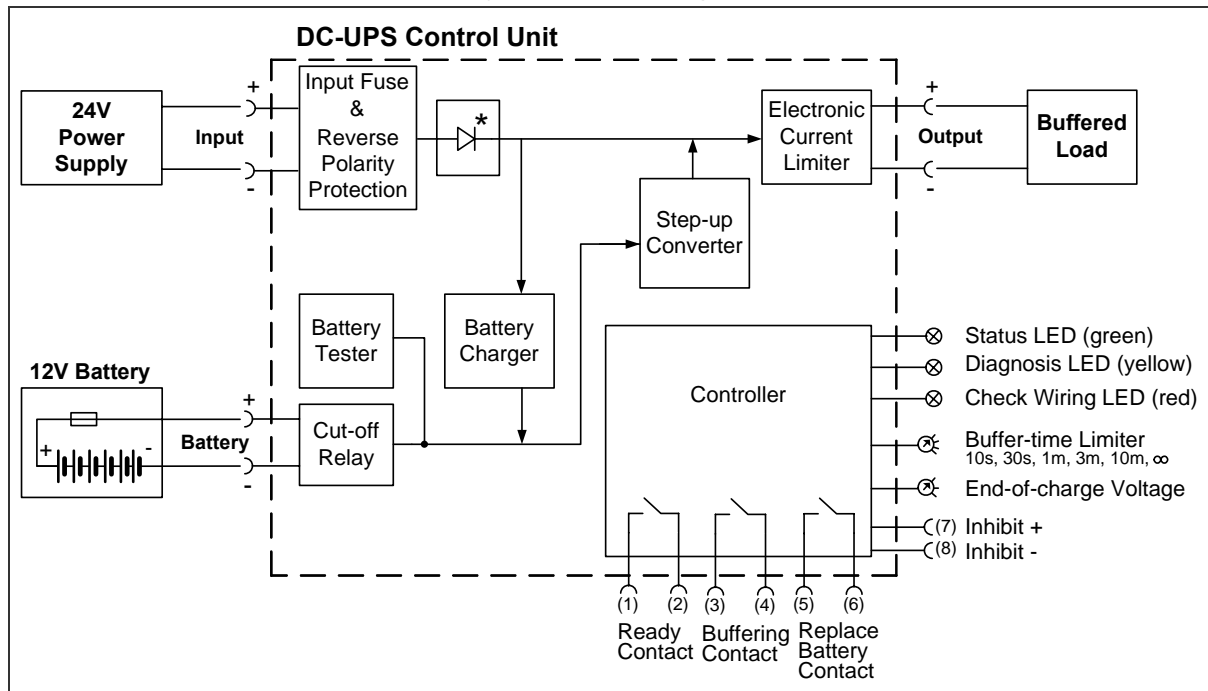

Fig. 10-2 Losses at 24V, typ.



11. FUNCTIONAL DIAGRAM

Fig. 11-1 Functional diagram



*) Return current protection; This feature utilizes a Mosfet instead of a diode in order to minimize the voltage drop and power losses.

June. 2010 / Rev. 1.3 DS-UB10.241-EN

All parameters are specified at an input voltage of 24V, 10A output load, 25°C ambient and after a 5 minutes run-in time unless otherwise noted. It is assumed that the input power source can deliver a sufficient output current.

12. CHECK WIRING AND BATTERY QUALITY TESTS

The DC-UPS is equipped with an automatic "Check Wiring" and "Battery Quality" test.

"Check Wiring" test:

Under normal circumstances, an incorrect or bad connection from the battery to the DC-UPS or a missing (or blown) battery fuse would not be recognized by the UPS when operating in normal mode. Only when back up is required would the unit not be able to buffer. Therefore, a "check wiring" test is included in the DC-UPS. This connection is tested every 10 seconds by loading the battery and analyzing the response from the battery. If the resistance is too high, or the battery voltage is not in range, the unit displays "Check Wiring" with the red LED. At the same time the green "Ready" LED will turn off.

"State of Health" (SoH) test:

The battery has a limited service life and needs to be replaced in a fixed interval which is defined by the specified service life (acc. to the Eurobat guideline), based on the surrounding temperature and the number of charging/discharging cycles. If the battery is used longer than the specified service life, the battery capacity will degrade. Details can be found in chapter 27.1. The battery SoH test can not determine a gradual loss in capacity. However, it can detect a battery failure within the specified service life of the battery. Therefore a SoH is included in the DC-UPS.

The battery quality test consists of different types of tests:

- During charging:
If the battery does not reach the ready status (see chapter 14) within 30h, it is considered to be defective. The reason could be a broken cell inside the battery.
- During operation:
Once the battery is fully charged, a voltage drop test and a load test is performed alternately every 8 hours. Three of the tests must consecutively produce negative results to indicate a battery problem.

A battery problem is indicated with the yellow LED (replace battery pattern) and the relay contact "Replace Battery". Please note that it can take up to 50 hours (with the largest size of battery) until a battery problem is reported. This should avoid nuisance error messages as any urgent battery problems will be reported by the "Check Wiring" test and create a warning signal. The battery tests require up to 50h uninterrupted operation. Any interruptions in the normal operation of the DC-UPS may result in the "Replace Battery" test cycle to start over.

When "Replace battery" is indicated, it is recommended to replace battery as soon as possible.

13. RELAY CONTACTS AND INHIBIT INPUT

The DC-UPS is equipped with relay contacts and signal inputs for remote monitoring and controlling of the unit.

Relay contacts:

- Ready: Contact is closed when battery is charged more than 85%, no wiring failure are recognized, input voltage is sufficient and inhibit signal is not active.
- Buffering: Contact is closed when unit is buffering.
- Replace Battery: Contact is closed when the unit is powered from the input and the battery quality test (SOH test) reports a negative result.

Relay contact ratings	max	60Vdc 0.3A, 30Vdc 1A, 30Vac 0.5A resistive load
	min	1mA at 5Vdc min.
Isolation voltage	max	500Vac, signal port to power port

Signal input:

Inhibit: The inhibit input disables buffering. In normal mode, a static signal is required. In buffer mode, a pulse with a minimum length of 250ms is required to stop buffering. The inhibit is stored and can be reset by cycling the input voltage. See also section 27.1 for application hints.

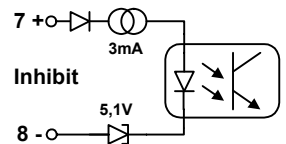

Signal voltage	max.	35Vdc
Signal current	max.	6mA, current limited
Inhibit threshold	min.	6Vdc, buffering is disabled above this threshold level
	max.	10Vdc
Isolation	nom.	500Vac, signal port to power port

Restriction apply when using the signal and relay contacts in a Haz-Loc environment:

The Buffering, Ready and Replace Battery contact is intended to be used for a separately investigated nonincendive field wiring and/or field wiring apparatus. The DC-UPS may be located in a Class I, Division 2 (Group A, B, C or D) hazardous (classified) location. Associated apparatus must be installed in accordance with its manufacturer's control drawing and Article 504 of the National Electrical Code (ANSI/NFPA 70) for installation in the United States, or Section 18 of the Canadian Electrical Code for Installations in Canada.

Selected associated apparatus must be third part listed as providing nonincendive field circuits for the application, and have Voc not exceeding Vmax, Isc not exceeding Imax.

Non associated nonincendive field wiring apparatuses shall not be connected in parallel unless this is permitted by the associated nonincendive field wiring apparatuses approval.

Fig. 13-1 **Contact control drawing for use in Haz-Loc environments**

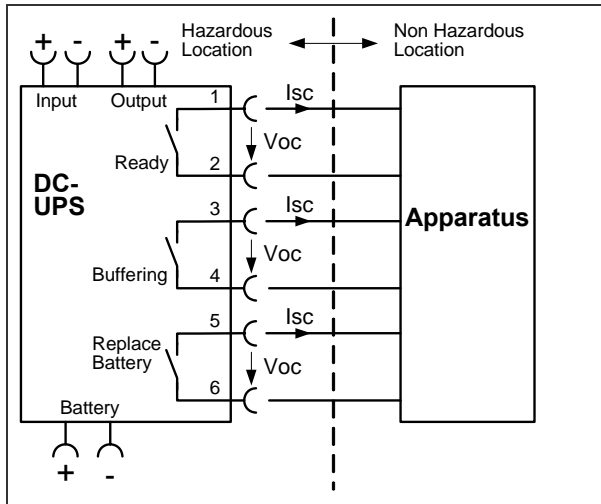

Selected barriers must have entity parameters such that
 $V_{oc} \leq V_{max}$, $I_{sc} \leq I_{max}$,
 $C_a \geq C_i + C_{cable}$, $L_a \geq L_i + L_{cable}$.
 For C_{cable} and L_{cable} , if the capacitance per foot
 or the inductance per foot is not known, then the
 following values shall be used: $C_{cable} = 60\text{pF/foot}$
 and $L_{cable} = 0.2\mu\text{H/foot}$.

Contact current: $I_{max} = 50\text{mA}$
 Contact voltage: $V_{max} = 35\text{V}$ (DC or AC)
 Max. associated circuit capacitance $C_i = 0$
 Max. associated circuit inductance $L_i = 0$
 No polarity requirement

14. FRONT SIDE USER ELEMENTS

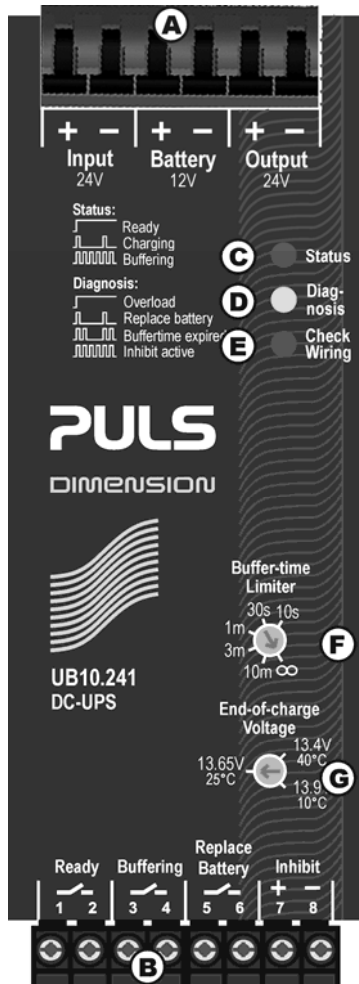

A Power Port

Quick-connect spring-clamp terminals, connection for input voltage, output voltage and battery

B Signal Port

Plug connector with screw terminals, inserted from the bottom. Connections for the Ready, Buffering, Replace Battery relay contacts and for the Inhibit input. See details in chapter 13.

C Green Status LED

Ready: Battery is charged > 85%, no wiring failure is recognized, input voltage is sufficient and inhibit signal is not active.

Charging: Battery is charging and the battery capacity is below 85%.

Buffering: Unit is in buffer mode.

Flashing pattern of the green status LED:

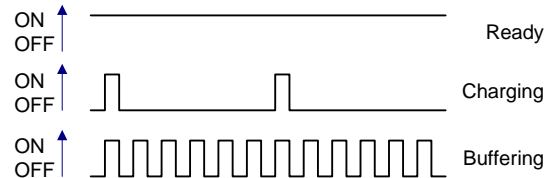

D Yellow Diagnosis LED

Overload: Output has switched off due to long overload in buffer mode or due to high temperatures.

Replace battery: Indicates a battery which failed the battery quality test (SoH test). Battery should be replaced soon.

Buffer-time expired: Output has switched off due to settings of Buffer-timer Limiter. This signal will be displayed for 15 minutes.

Inhibit active: Indicates that buffering is disabled due to an active inhibit signal.

Flashing pattern of the yellow diagnosis LED:

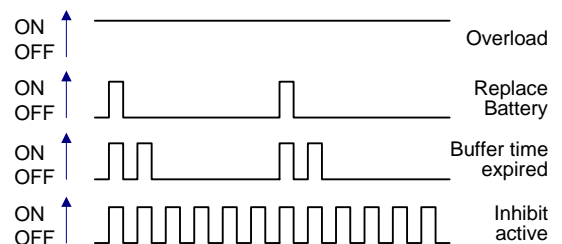

E Red Check Wiring LED

This LED indicates a failure in the installation (e.g. too low input voltage), wiring, battery or battery fuse.

F Buffer-time Limiter:

User accessible dial which limits the maximum buffer time in a buffer event to save battery energy. When the battery begins to recharge after a discharging event, the process is completed much faster since only the energy which was taken out of the battery needs to be "refilled". The following times can be selected: 10 seconds, 30 seconds, 1 minute, 3 minutes, 10 minutes or infinity (until battery is flat) which allows buffering until the deep discharge protection stops buffering.

G End-of-charge-voltage Selector:

The end-of-charge-voltage shall be set manually according to the expected temperature in which the battery is located. The dial on the front of the unit allows a continuous adjustment between +10 and +40°C. 10°C will set the end-of-charge-voltage to 13.9V, 25°C→13.65V and 40°C→13.4V. If in doubt about the expected temperature, set the unit to 35°C.

June. 2010 / Rev. 1.3 DS-UB10.241-EN

All parameters are specified at an input voltage of 24V, 10A output load, 25°C ambient and after a 5 minutes run-in time unless otherwise noted. It is assumed that the input power source can deliver a sufficient output current.

15. TERMINALS AND WIRING

	Power terminals	Signal terminals
Type	Bi-stable, quick-connect spring-clamp terminals. IP20 Finger-touch-proof. Suitable for field- and factory installation. Shipped in open position.	Plug connector with screw terminal. Finger-touch-proof construction with captive screws for 3.5mm slotted screwdriver. Suitable for field- and factory installation. Shipped in open position. To meet GL requirements, unused terminal compartments should be closed.
Solid wire	0.5-6mm ²	0.2-1.5mm ²
Stranded wire	0.5-4mm ²	0.2-1.5mm ²
AWG	20-10AWG	22-14AWG
Ferrules	Allowed, but not required	Allowed, but not required
Pull-out force	10AWG:80N, 12AWG:60N, 14AWG:50N, 16AWG:40N according to UL486E	Not applicable
Tightening torque	Not applicable	0.4Nm, 3.5lb.in
Wire stripping length	10mm / 0.4inch	6mm / 0.24inch

Fig. 15-1 **Spring-clamp terminals, connecting a wire**

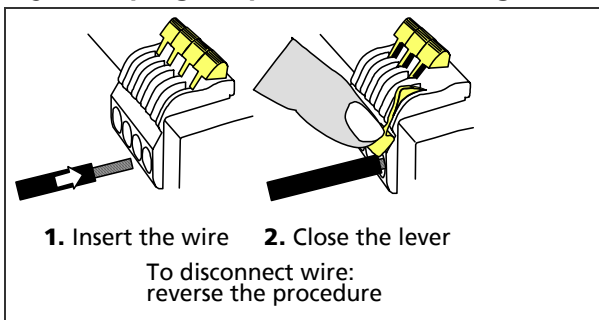

Instructions:

- Use appropriate copper cables, that are designed for an operating temperature of 60°C
- Follow national installation codes and regulations!
- Ensure that all strands of a stranded wire enter the terminal connection!
- Up to two stranded wires with the same cross section are permitted in one connection point

16. RELIABILITY

Lifetime expectancy	min.	137 400h	At 10A output current, 40°C
	min.	> 15 years	At 5A output current, 40°C
	min.	> 15 years	At 10A output current, 25°C
MTBF SN 29500, IEC 61709		886 000h	At 10A output current, 40°C
		1 482 000h	At 10A output current, 25°C
MTBF MIL HDBK 217F		397 900	At 10A output current , 40°C, ground benign GB40
		545 000	At 10A output current , 25°C, ground benign GB25

The **Lifetime expectancy** shown in the table indicates the operating hours (service life) and is determined by the lifetime expectancy of the built-in electrolytic capacitors. Lifetime expectancy is specified in operational hours. Lifetime expectancy is calculated according to the capacitor's manufacturer specification. The prediction model allows a calculation of up to 15 years from date of shipment.

MTBF stands for **Mean Time Between Failure**, which is calculated according to statistical device failures and indicates reliability of a device. It is the statistical representation of the likelihood of a unit to fail and does not necessarily represent the life of a product.

17. EMC

The unit is suitable for applications in industrial environment as well as in residential, commercial and light industry environment without any restrictions. CE mark is in conformance with EMC guideline 89/336/EEC and 93/68/EEC and the low-voltage directive (LVD) 73/23/EEC, 93/68/EEC.

A detailed EMC Report is available on request.

EMC Immunity	EN 61000-6-1, EN 61000-6-2	Generic standards		
Electrostatic discharge	EN 61000-4-2	Contact discharge	8kV	Criterion A*)
		Air discharge	15kV	Criterion A *)
Electromagnetic RF field	EN 61000-4-3	80MHz-1GHz	10V/m	Criterion A
Fast transients (Burst)	EN 61000-4-4	Out- and input lines	2kV	Criterion A
		Signal lines **)	2kV	Criterion A
Surge voltage	EN 61000-4-5	Output + → -	500V	Criterion A
		Input + → -	500V	Criterion A
		+ / - → housing	500V	Criterion A
Conducted disturbance	EN 61000-4-6	0,15-80MHz	10V	Criterion A

*) DIN-Rail earthed

***) Tested with coupling clamp

EMC Emission	EN 61000-6-3, EN 61000-6-4	Generic standards		
Conducted emission	EN 55022	Input lines	Class B *)	
		Output lines	Class B *)	
Radiated emission	EN 55011, EN 55022	Class B		

This device complies with FCC Part 15 rules.

Operation is subjected to the following two conditions: (1) this device may not cause harmful interference, and (2) this device must accept any interference received, including interference that may cause undesired operation.

*) Informative measurement with voltage probe

Switching frequencies

The DC-UPS has three converters with three different switching frequencies included.

Switching frequency of boost converter	100kHz	Constant frequency
Switching frequency of electronic output current limitation	78kHz	Constant frequency
Switching frequency of battery charger	19.5kHz	Constant frequency

18. ENVIRONMENT

Operational temperature	-25°C to +70°C (-13° to +158°F)	For the DC-UPS control unit. Keep battery in a cooler environment!
Derating	0.43A/°C	+60°C to +70°C (+140°F to +158°F), normal mode see Fig. 18-1
	0.25A/°C	+60°C to +70°C (+140°F to +158°F), buffer mode see Fig. 18-2
Storage temperature	-40 to +85°C (-40° to +185°F)	Storage and transportation, except battery
Humidity	5 to 95% r.H.	IEC 60068-2-30 Do not energize while condensation is present
Vibration sinusoidal	2-17.8Hz: ±1.6mm; 17.8-500Hz: 2g	IEC 60068-2-6
Shock	30g 6ms, 20g 11ms	IEC 60068-2-27
Altitude	0 to 6000m	Approvals apply only up to 2000m
Over-voltage category	III	EN 50178
	II	EN 50178 above 2000m altitude
Degree of pollution	2	EN 50178, not conductive

Fig. 18-1 Output current vs. ambient temperature

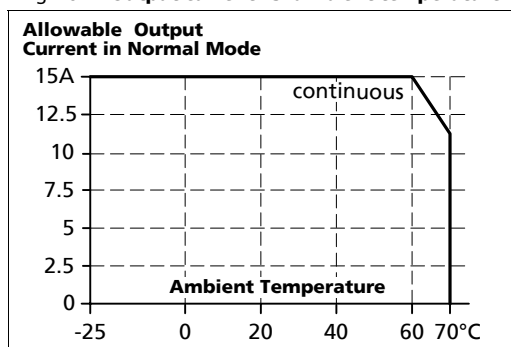
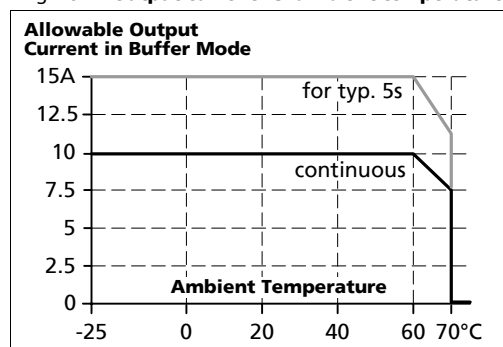

Fig. 18-2 Output current vs. ambient temperature



The ambient temperature is defined 2cm below the unit.

19. PROTECTION FEATURES

Output protection	Electronically protected against overload, no-load and short-circuits	
Output over-voltage protection in buffer mode	typ. 32Vdc max. 35Vdc	In case of an internal defect, a redundant circuitry limits the maximum output voltage. The output automatically shuts-down and makes restart attempts.
Degree of protection	IP20	EN/IEC 60529
Penetration protection	> 3.5mm	E.g. screws, small parts
Reverse battery polarity protection	yes	Max. -35Vdc;
Wrong battery voltage protection	yes	Max. +35Vdc (e.g. 24V battery instead of 12V battery)
Battery deep discharge protection	yes	The limit is battery current dependent
Over temperature protection	yes	Output shut-down with automatic restart
Input over-voltage protection	yes	Max. 35Vdc, no harm or defect of the unit
Internal input fuse	25A, blade type	No user accessible part, no service part





June. 2010 / Rev. 1.3 DS-UB10.241-EN

All parameters are specified at an input voltage of 24V, 10A output load, 25°C ambient and after a 5 minutes run-in time unless otherwise noted. It is assumed that the input power source can deliver a sufficient output current.

20. SAFETY

Output voltage	SELV PELV Max. allowed voltage between any input, output or signal pin and ground: 60Vdc or 42.4Vac	IEC/EN 60950-1 EN 60204-1, EN 50178, IEC 60364-4-41
Class of protection	III	PE (Protective Earth) connection is not required
Isolation resistance	> 5MΩ	Power port to housing, 500Vdc
Dielectric strength	500Vac	Power port to signal port
	500Vac	Power port / signal port to housing
Touch current (leakage current)	The leakage current which is produced by the DC-UPS itself depends on the input voltage ripple and need to be investigated in the final application. For a smooth DC input voltage, the produced leakage current is less than 100µA.	

21. APPROVALS

UL 508		LISTED E198865 listed for use in U.S.A. (UL 508) and Canada (C22.2 No. 14-95) Industrial Control Equipment
UL 60950-1		RECOGNIZED E137006 recognized for the use in U.S.A. (UL 60950-1) and Canada (C22.2 No. 60950) Information Technology Equipment, Level 5
IEC 60950-1		CB Scheme, Information Technology Equipment
UL 1604		RECOGNIZED E246877 recognized for use in U.S.A. (UL 1604) and Canada (C22.2 No. 213-M1987) Hazardous Location Class I Div 2 T4 Groups A,B,C,D and Class I Zone 2 Groups IIA, IIB and IIC The unit is suitable for use in Class I Division 2 Groups A, B, C, D locations as well as for Class I Zone 2 Groups IIA, IIB and IIC locations. Substitution of components may impair suitability for Class I Division 2 environment. Do not disconnect equipment unless power has been switched off. Wiring must be in accordance with Class I, Division 2 wiring methods of the National Electrical Code, NFPA 70, and in accordance with other local or national codes.
Marine		GL (Germanischer Lloyd) classified and ABS (American Bureau for Shipping) PDA for marine and offshore applications. Environmental category: C, EMC2

22. FULFILLED STANDARDS

EN/IEC 60204-1	Safety of Electrical Equipment of Machines
EN/IEC 61131	Programmable Controllers
EN 50178, IEC 62103	Electronic Equipment in Power Installations

June. 2010 / Rev. 1.3 DS-UB10.241-EN

All parameters are specified at an input voltage of 24V, 10A output load, 25°C ambient and after a 5 minutes run-in time unless otherwise noted. It is assumed that the input power source can deliver a sufficient output current.

23. USED SUBSTANCES

The unit does not release any silicone and is suitable for the use in paint shops.

The unit conforms to the RoHS directive 2002/96/EC.

Electrolytic capacitors included in this unit do not use electrolytes such as Quaternary Ammonium Salt Systems.

Plastic housings and other molded plastic materials are free of halogens, wires and cables are not PVC insulated.

The materials used in our production process do not include the following toxic chemicals:

Polychlorinated Biphenyl (PCB), Pentachlorophenol (PCP), Polychlorinated naphthalene (PCN), Polybrominated Biphenyl (PBB), Polybrominated Biphenyl Oxide (PBO), Polybrominated Diphenyl Ether (PBDE), Polychlorinated Diphenyl Ether (PCDE), Polybrominated Diphenyl Oxide (PBDO), Cadmium, Asbestos, Mercury, Silica

24. PHYSICAL DIMENSIONS AND WEIGHT

Width	49mm / 1.93"	
Height	124mm / 4.88"	Plus height of signal connector plug
Depth	117mm / 4.61"	Plus depth of DIN-rail
Weight	530g / 1.17lb	
DIN-Rail	Use 35mm DIN-rails according to EN 60715 or EN 50022 with a height of 7.5 or 15mm. The DIN-rail height must be added to the depth (117mm) to calculate the total required installation depth.	

Electronic files with mechanical data can be downloaded at www.pulspower.com

Fig. 24-1 Side view

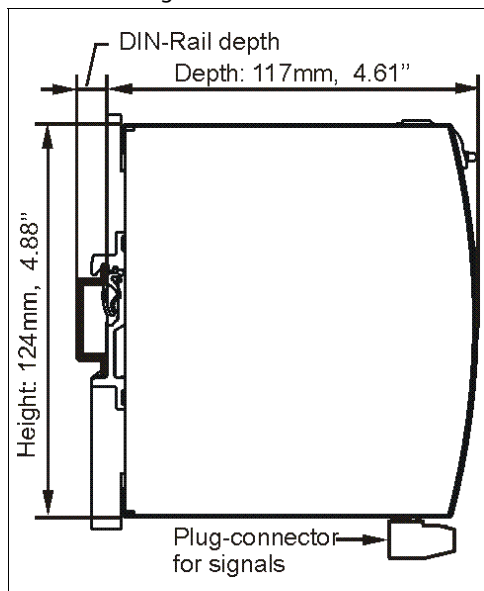
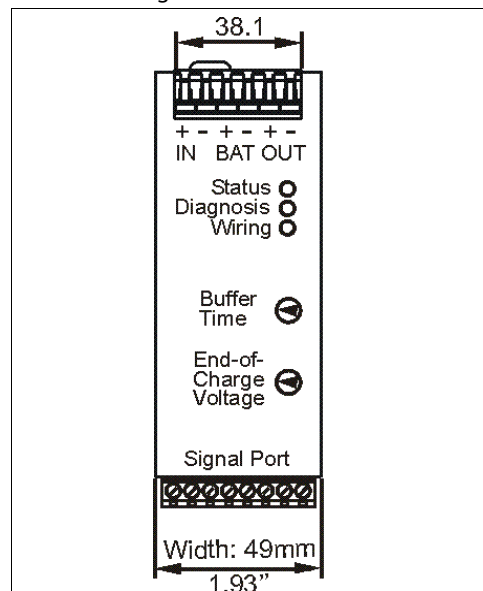

Fig. 24-2 Front view



25. INSTALLATION NOTES

Mounting:

The power terminal shall be located on top of the unit. An appropriate electrical and fire end-product enclosure should be considered in the end use application.

Cooling: Convection cooled, no forced air cooling required. Do not obstruct air flow!

Installation clearances: 40mm on top, 20mm on the bottom, 5mm on the left and right side are recommended when loaded permanently with full power. In case the adjacent device is a heat source, 15mm clearance are recommended.

Risk of electrical shock, fire, personal injury or death!

Turn power off and disconnect battery fuse before working on the DC-UPS. Protect against inadvertent re-powering. Make sure the wiring is correct by following all local and national codes. Do not open, modify or repair the unit. Use caution to prevent any foreign objects from entering into the housing. Do not use in wet locations or in areas where moisture or condensation can be expected.

Service parts:

The unit does not contain any service parts. The tripping of an internal fuse is caused by an internal fault. If damage or malfunctioning should occur during operation, immediately turn power off and send unit to the factory for inspection!

Wiring and installation instructions:

- (1) Connect the power supply to the input terminals of the DC-UPS.
- (2) Connect the battery to the battery terminals of the DC-UPS. It is recommended to install the battery outside the cabinet or in a place where the battery will not be heated up by adjacent equipment. Do not install the battery in airtight housings or cabinets. The battery should be installed according to EN50272-2, which includes sufficient ventilation. Batteries store energy and need to be protected against energy hazards. Use a 30A battery fuse typ ATO® 257 030 (Littelfuse) or similar in the battery path. The battery fuse protects the wires between the battery and the DC-UPS. It also allows the disconnection of the battery from the DC-UPS which is recommended when working on the battery or DC-UPS. Disconnect battery fuse before connecting the battery.
Please note: Too small or too long wires between the DC-UPS and the battery can shorten the buffer time or can result in a malfunction of the DC-UPS. Do not use wires smaller than 2.5mm² (or 12AWG) and not longer than 2x1.5m (cord length 1.5m). Avoid voltage drops on this connection.
- (3) Connect the buffered load to the output terminals of the DC-UPS. The output is decoupled from the input allowing load circuits to be easily split into buffered and non buffered sections. Noncritical loads can be connected directly to the power supply and will not be buffered. The energy of the battery can then be used in the circuits which requires buffering.
- (4) Install the fuse when the wiring is finished.

Fig. 25-1 Typical wiring diagram

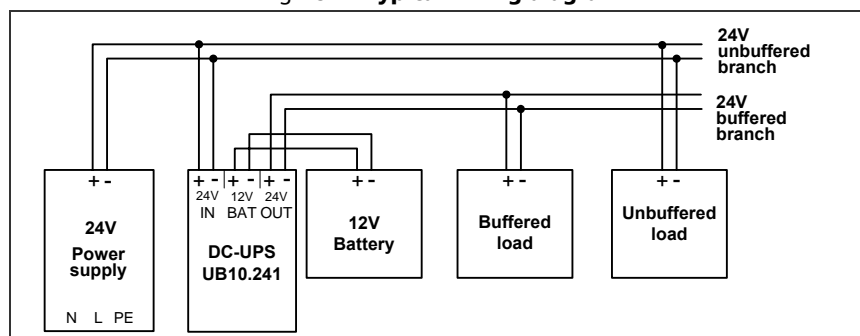

June. 2010 / Rev. 1.3 DS-UB10.241-EN

All parameters are specified at an input voltage of 24V, 10A output load, 25°C ambient and after a 5 minutes run-in time unless otherwise noted. It is assumed that the input power source can deliver a sufficient output current.

26. ACCESSORIES

Battery Modules

Two pre-assembled battery modules with a single 12V battery are available for different buffer times. As an option, the mounting brackets are also available without batteries. This option offers more flexibility in selecting an appropriate battery or can save shipping and logistic costs. See individual datasheets for detailed information.

	UZK12.071	UZK12.261	
Battery type	Standard version 12V, 7Ah	High current version 12V, 26Ah	VRLA lead-acid maintenance free battery
Service life	3 to 5years	10 to 12years	According to EUROBAT guideline
Dimensions	155x124x112mm	214x179x158mm	Width x height x depth
Weight	3.2kg	9.9kg	
DIN-Rail mountable	yes	no	
Order number	UZK12.071 UZO12.07 UZB12.071	UZK12.261 UZO12.26 UZB12.261	Battery module Mounting bracket without battery Replacement battery only

Fig. 26-1 **UZK12.071**



Fig. 26-2 **UZK12.261**



ZM1.WALL Wall / Panel mounting bracket

This bracket is used to mount the DC-UPS units onto a flat surface without utilizing a DIN-Rail. The two aluminum brackets and the black plastic slider of the DC-UPS have to be removed so that the two surface brackets can be mounted.

Fig. 26-3 **ZM1.WALL Wall / Panel Mounting Bracket**

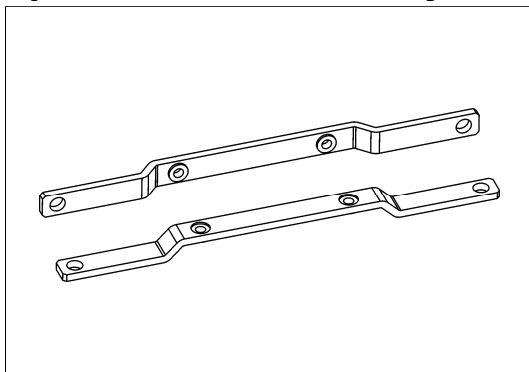
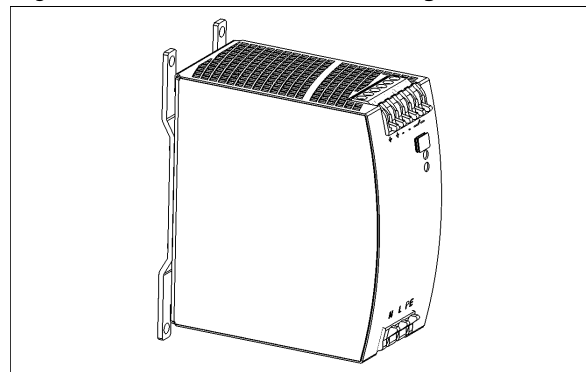

Fig. 26-4 **Assembled Wall / Panel Mounting Bracket**



27. APPLICATION NOTES

27.1. BATTERY REPLACEMENT INTERVALS

Batteries have a limited life time. They degrade slowly beginning from the production and need to be replaced periodically. The design life figures can be found in the individual datasheets of the batteries and usually is specified according to the Eurobat guideline or according to the manufacturer's specifications.

The design life is the estimated life based on laboratory condition, and is quoted at 20°C using the manufacturer's recommended float voltage condition. According to the Eurobat guideline, design lives have been structured into the following different groups:

- 3 - 5 years: This group of batteries is very popular in standby applications and in small emergency equipment. This represents a 4 years design life with a production tolerance of ± 1 year.
- 6 - 9 years: This group of batteries is usually used when an improved life is required. This represents a 7.5 years design life with a production tolerance of ± 1.5 years.
- 10 - 12 years: This group of batteries is used when in applications where longest life and highest safety level are required. This represents a 11 years design life with a production tolerance of ± 1 year.

A battery failure within the specified design life of the battery usually results in a complete loss of the battery function (broken cell, defect connection, ...) and will be detected and reported by the periodical battery tests which are included in the UB10.241 DC-UPS control unit.

If the operational parameters differ from those which are specified for the design life, an earlier change of the battery might be necessary. The "real life" is called service life and is defined as the point at which the cell's actual capacity has reached 80% of its nominal capacity. At the end of the service life the capacity degrades much faster, so that a further use of the battery is not recommended.

Temperature effect:

The temperature has the most impact in the service life. The hotter the temperature, the earlier the wear-out phase of the battery begins. The wear-out results in a degradation of battery capacity. See Fig. 27-1 for details.

Effect of discharging cycles

The number as well as the depth of discharging cycles is limited. A replacement of the battery might be necessary earlier than the calculated service life if the battery exceeds the numbers and values of Fig. 27-2.

Other effects which shortens the service life

- Overcharging and deep discharging shortens the service life and should be avoided. Thanks to the single battery concept of the UB10.241, the end-of-charge-voltage can be set very precisely to the required value and thereby avoiding unnecessary aging effects.
- Charge retention is important to get the longest battery life. Stored batteries which are not fully charged age faster than charged batteries. Batteries which are not in use should be recharged at least once a year.
- Excessive float charge ripple across the battery has an effect of reducing life and performance. The UB10.241 does not produce such a ripple voltage. This effect can be ignored when the battery is charged with the UB10.241.

Guidelines for a long battery service life:

- Place the battery in a cool location: E.g. near the bottom of the control cabinet.
- Do not place the battery near heat generating devices.
- Do not store discharged batteries.
- Do not discharge the battery more than necessary. Set buffer time limiter to the required buffer time.
- When choosing the battery capacity, always try to get the next higher capacity than required. The depth of discharge reduces the service life of the battery and limits the number of cycles. See Fig. 27-2.

June. 2010 / Rev. 1.3 DS-UB10.241-EN

All parameters are specified at an input voltage of 24V, 10A output load, 25°C ambient and after a 5 minutes run-in time unless otherwise noted. It is assumed that the input power source can deliver a sufficient output current.

Example for calculating the service life and the required replacement cycle:

Parameters for the example:

- A 7Ah battery with a design life of 3-5 years is used (e.g. Yuasa battery from the battery module UZK12.071)
- The average ambient temperature is 30°C
- One buffer event consumes approx. 25% of the achievable buffer time.
- One buffer event per day

Calculation:

Ambient temperature influence:

According to Fig. 27-1 curve A, a 2 years service life can be expected for an ambient temperature of 30°C.

Number of discharging cycles: 2 years * 365 cycles = 730cycles in 2 years.

According to Fig. 27-2, curve C has to be used (only 25% of battery capacity is required). 730 cycles have only a negligible influence in a battery degradation and can be ignored.

Result:

The battery shall be replaced after 2 years.

Please note that the battery degrading begins from the production date (check date code on the battery) which may shorten the replacement intervals.

Fig. 27-1 Service life versus ambient temperatures, typ *)

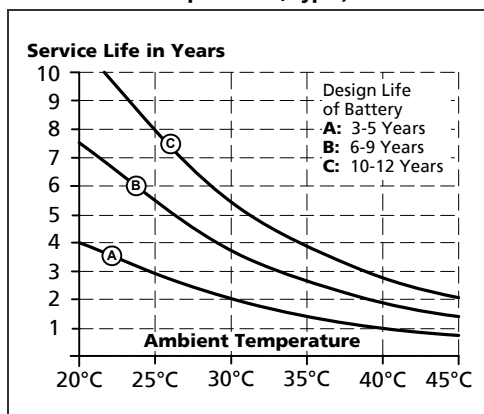
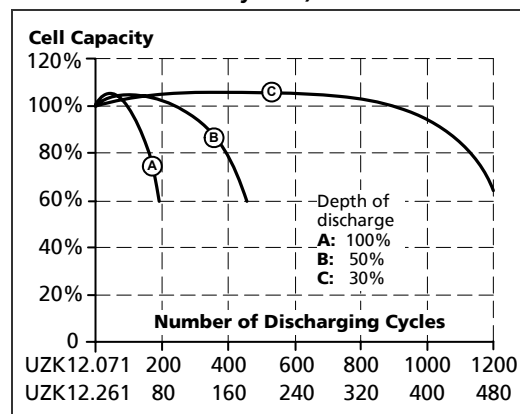

Fig. 27-2 Cell capacity degradation vs. discharging cycles *)



*) datasheet figures from battery manufacturer

27.2. PARALLEL AND SERIAL USE

Do not use the DC-UPS in parallel to increase the output power. However, two units of the DC-UPS can be paralleled for 1+1 redundancy to gain a higher system reliability.

Do not use batteries in parallel, since the battery quality test might create an error message.

Do not connect two or more units in series for higher output voltages.

Do not connect two or more units in a row to get longer hold-up times.

27.3. USING THE INHIBIT INPUT

The inhibit input disables buffering. In normal mode, a static signal is required. In buffer mode, a pulse with a minimum length of 250ms is required to stop buffering. The inhibit is stored and can be reset by cycling the input voltage.

For service purposes, the inhibit input can also be used to connect a service switch. Therefore, the inhibit signal can be supplied from the output of the DC-UPS.

Fig. 27-3 **Wiring example for inhibit input**

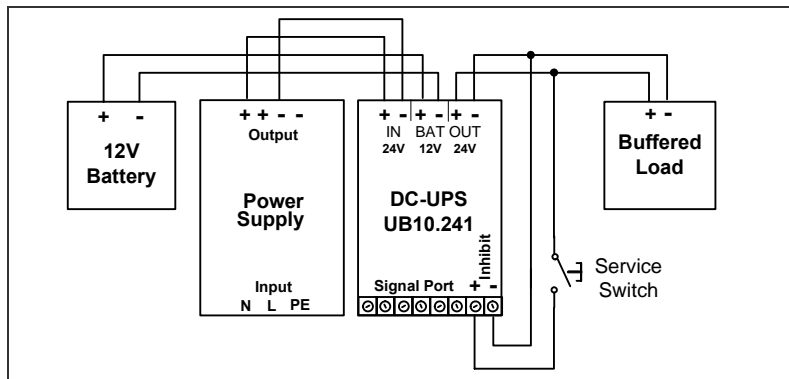

27.4. TROUBLESHOOTING

The LEDs on the front of the unit and relay contacts indicate about the actual or elapsed status of the DC-UPS. Please see also chapter 14.

The following guidelines provide instructions for fixing the most common failures and problems. Always start with the most likely and easiest-to-check condition. Some of the suggestions may require special safety precautions. See notes in section 25 first.

- “Check wiring” LED is on** Check correct wiring between the battery and the DC-UPS
 Check battery fuse. Is the battery fuse inserted or blown?
 Check battery voltage (must be typically between 7.4V and 15.1V)
 Check input voltage (must be typically between 22.8V and 30V)
 Check battery polarity
- DC-UPS did not buffer** Inhibit input was set
 Battery did not have enough time to be charged and is still below the deep discharge protection limit.
- DC-UPS stopped buffering** Buffer time limiter stopped buffering → set buffer time limiter to a higher value
 Deep discharge protection stopped buffering → use a larger battery, or allow sufficient time for charging the battery
 Output was overloaded or short circuit → reduce load
- Output has shut down** Cycle the input power to reset the DC-UPS
 Let DC-UPS cool down, over temperature protection might have triggered.
- DC-UPS constantly switches between normal mode and buffer mode**
 The supplying source on the input is too small and can not deliver sufficient current
 → Use a larger power supply or reduce the output load

June. 2010 / Rev. 1.3 DS-UB10.241-EN
 All parameters are specified at an input voltage of 24V, 10A output load, 25°C ambient and after a 5 minutes run-in time unless otherwise noted. It is assumed that the input power source can deliver a sufficient output current.