



ALFA35 - ALFA36



Features	Unit	ALFA3000BPB	ALFA3500BPB	ALFA3510BPB	ALFA3540BPB	ALFA3600BPB	ALFA3610BPB
Air flow rate (free blow)	m ³ /h	-	500(570)			630(700)	
Flow rate with exit filter	m ³ /h	-	370(410)			470(520)	
Power supply	V/Hz	-	230/50-60	115/50-60	400/50-60	230/50-60	115/50-60
Dimensions HxWxD	mm	325x325x30	325x325x151				
Power consumption	W	-	70(90)		60(70)	130(180)	
Current consumption	A	-	0.40(0.38)	0.80(0.76)	0.18(0.15)	0.55(0.81)	1.10(1.62)
Overcurrent protection	-	-	thermal				
Electric connection	-	-	3-pole terminal 2.5 mm ²			4-pole terminal 1.5 mm ²	
Duty cycle	-	-	100%				
Operating temperature	°C	-	-10/+70				
Protection degree/class	-	IP54	IP54/Class I				
Noise level	dB(A)	-	65(68)			72(73)	
Flow direction	-	-	outside-in				
Bearing	-	-	ball				
Filter mat (Eurovent)	-	EU3					
Service life (at 40°C)	hr	-	50,000				
Material	-	ABS UL94V-0 Color RAL7035					
Wall thickness	mm	1.2-2.4					
Gasket	-	self-adhesive					
Weight (with packaging)	kg	0.64(0.78)	3.00(3.25)			3.65(3.90)	
Package dimensions	mm	340x340x45	340x340x175				
Mounting	-	Fast Clip-on					
Conformity/Approvals	-	CE					

Versions

UL File n. E301228	ALFA3000BPB	ALFA3500BPB	ALFA3510BPB	-	ALFA3600BPB	-
RAL7032 - Gray - Code ending	delete B					
RAL9005 - Black - Code ending	delete B, add N (available on request)					
EMC - Code ending	M					
Reverse flow - Code ending	-	PR				

Accessories

Filter mat, standard type	ALFAFBP30					
Filter mat, high efficiency	ALFAFBP30X					
Thermostat 0-60°C, NO contact	-	THV2				
Fan speed controller	-	FSC				
Hood for IP55	CUFF30B					

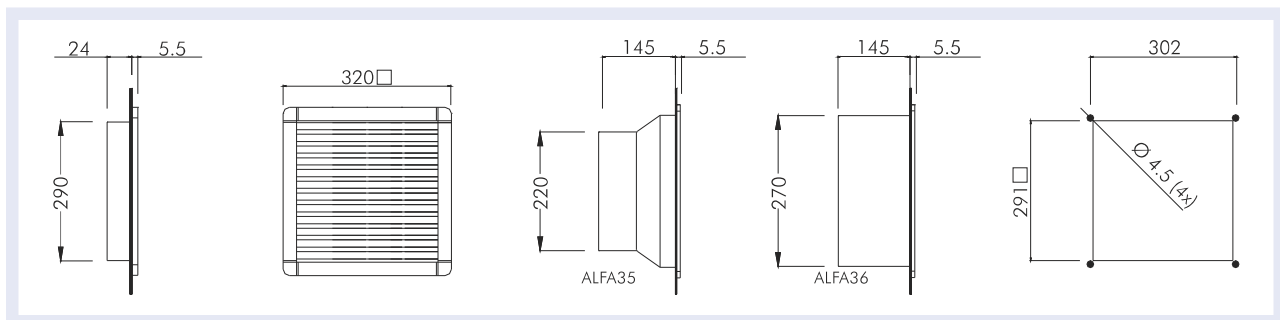

ael-cat-en-13.01